



POWER MONITORING PRODUCTS

VAF & VAPPF METER | ENERGY METERS | MULTIFUNCTION METERS
TRI VECTOR METER | DEMAND CONTROLLER

COMPANY

Harmonizer India Pvt Ltd., is a Knowledge based organization providing services, solutions and world class products to our customers. We believe in Intellectual driven business that will help customers to understand the concepts in depth and enable customers a great mind share on the business we are in.

With multi-dimensional expertise we are able to deliver what we commit with a great sense of customer delight. We have more than 40+ years of combined experience in the field of Power Quality, Electro Magnetic Interference (EMI), Harmonic Audit and solutions, Energy Audits & Solutions, Software for Power Quality Simulation and in-depth expertise in IoT solutions, Agile software development, Machine Learning algorithm, AI algorithm for Engineering domain.

With Head office in Bengaluru, we have an operations in UAE & Canada.

VISION

To provide knowledge driven business solutions for our customers that will enable sustainability, productivity & reliability of electrical network.



1 & 3 VAF and 3 VAFPF Meters



3-Phase Volt Meter



VAFPF Meter



Harmonizer's Basic series meters are easy-to-operate, compact in size, cost effective meters that offer the basic measurement capabilities required to monitor an electrical installation.

Characterized by their rugged construction, compact size, and low installation costs, these state-of-the-art Basic meters are ideal for control panels, motor control centers and in any ac electric panel.

Basic series meters are available in six versions to better fit specific applications:

- SPA01 Series
- SPV01 Series
- SPF01 Series
- TPA04 Series
- TPV08 Series
- VAF17 Series

Applications:

- AC Current Display
- AC Voltage Display
- Frequency Display
- PF Display

MAIN CHARACTERISTICS

● Accurate Metering

The meter conforms to accuracy class 1.0 / 0.5

● Easy to Read Display

The bright, alphanumeric, 15mm high LED display provides 3 lines for measurement values with 4 digits per line. The display auto-scales for Kilo, Mega and Giga values. Auto scrolling mode allows for easy reading.

● Quick And Easy Installation

Setup is done through the front panel keys. Direct connection for metering voltage inputs up to 480 Vac L-L.

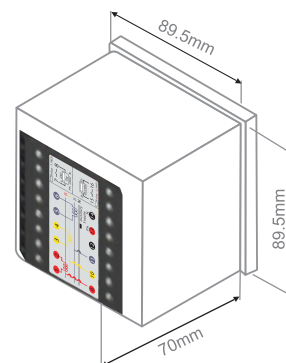

Multifunction Meter Dimensions

● Colour-coded Terminal Board Labeling

The colour - coded label on the terminal board helps ensure accurate wiring.

● Secure Settings

Safeguard access to setup parameters with unique password protection. A keypad lock lets you display a user selected page by default.

1 & 3 VAF and 3 VAFPF Meters



Selection guide		SPA01	SPV01	SPF01	TPA04	TPV08	VAF17	VAFPF17
General								
Use on LV and HV systems		■	■	■	■	■	■	■
Accuracy of the meter		□	□	■	□	□	□	□
Number of samples per cycle		50 at 50 Hz	50 at 50 Hz	50 at 50 Hz	50 at 50 Hz	50 at 50 Hz	50 at 50 Hz	50 at 50 Hz
Instantaneous rms values								
Current	Per phase	■	—	—	—	—	■	■
	Total & Per Phase	—	—	—	■	—	■	■
	Neutral	—	—	—	■	—	■	■
Voltage	Phase to Phase	—	■	—	—	■	■	■
	Average & Phase to Neutral	—	—	—	—	■	■	■
Frequency		—	—	■	—	—	■	■
Power factor per phase & average		—	—	—	—	—	—	■
Display								
LED display		■	■	■	■	■	■	■
Communication								
RS-485 port		—	—	—	—	—	—	□
Modbus protocol		—	—	—	—	—	—	□

■ By Default □ Optional Features — Not Available

Ordering Selection

	SPA01	SPV01	SPF01	TPA04	TPV08	VAF17	VAFPF17	
Class 1.0	HA011SPA	HA011SPA		HA0410TPA	HA0810TPV	HA1710VAF	Without RS485	HA1710VAF
Class 0.5	HA051SPA	HA051SPA		HA0405TPA	HA0805TPV	HA1705VAF	HA1705VAF	
Class 0.5			HA02SPF				HA1705VAFP HA1705VAFPR	

Single Source / Dual Source Energy Meters



Whole Current Dual Source Meter



Dual Source Meter



Harmonizer's Energy Meter Series are easy-to-operate, compact in size, cost effective meters that offer the basic measurement capabilities required to monitor an electrical installation.

Characterized by their rugged construction, compact size, and low installation costs, these state-of-the-art energy meters are ideal for control panel, residential apartments, malls and housing society.

Energy Meter Series are available in six versions to better fit specific applications:

- EN34 Series
- DSR10 Series
- DSR10 Series
- MFDSR28 Series

Applications:

- Single Source Metering
- Dual Source Metering
- Separate Load Control Limits for EB & DG

MAIN CHARACTERISTICS

● Accurate Metering

The meter conforms to accuracy class 1.0 / 0.5

● Easy to Read Display

The bright, alphanumeric, 15mm high LED display provides 3 lines for measurement values with 4 digits per line. The display auto-scales for Kilo, Mega and Giga values. Auto scrolling mode allows for easy reading.

● Quick And Easy Installation

Setup is done through the front panel keys. Direct connection for metering voltage inputs up to 480 Vac L-L.

ENERGY SAVINGS:

- Measure efficiency, reveal opportunities and verify savings
- Sub-bill tenants for energy costs
- Allocate energy costs to departments or processes.
- Reduce peak demand surcharges.
- Reduce power factor penalties.
- Leverage existing infrastructure capacity & avoid over-building.

● Colour-coded Terminal Board Labeling

The colour - coded label on the terminal board helps ensure accurate wiring.

● Secure Settings

Safeguard access to setup parameters with unique password protection. A keypad lock lets you display a user selected page by default.

Single Source / Dual Source Energy Meters



Selection guide	DSR10	E N34	DSRR10	MFDSR28
General				
Use on LV and HV systems	■	■	■	■
Accuracy of the meter	□	□	□	□
Number of samples per cycle	50 at 50 Hz	50 at 50 Hz	50 at 50 Hz	50 at 50 Hz
Instantaneous rms values				
Current, Total, Per phase & Neutral	■	—	■	■
Voltage, Average, Phase to Neutral & Phase to Phase	—	—	—	■
Frequency	—	—	—	■
Active power (W) Total & per phase	■	—	■	■
Reactive power (VAr) Total & per phase	—	—	—	—
Apparent power (VA) Total & per phase	■	—	■	■
Power factor Average & per phase	—	—	—	■
RPM For generator only, speed calculated on generator voltage output and number of machine poles.	—	—	—	—
Energy values				
Active (Wh)	■	* ■	■	■
Reactive (VARh)	—	—	—	—
Apparent energy (VAh)	■	* ■	■	■
Single Source Metering	■	■	■	■
Dual Source Metering	■	—	■	■
Mounting				
Wall Mounted	—	—	—	—
Panel Mounted	■	■	■	■
Relay				
Relay - 1	—	—	■	□
Relay - 2	—	—	■	□
Display				
LED display	—	●	●	●
Communication				
RS-485 port	■	□	■	■
Modbus protocol	■	□	■	■
Calibration				
LED Pulse Output for Calibration	■	■	■	■

- 3 Line LED Display ▲ Counter Display ■ By Default
- Optional Features — Not Available * Wh/Vah one will be selected programmable

Ordering Selection

	DSR10	E N34	DSRR10	MFDSR28
Class 1.0	HA1010DSR	HA3410EN	HA1010DSRR	HA2810MFDSR
Class 0.5	HA1005DSR	HA3405EN	HA1005DSRR	HA2805MFDSR
Class 1.0 with Relay O/P			HA1010DSRR	
Class 0.5 with Relay O/P			HA1005DSRR	

Multi-function Meters



Multifunction Meter

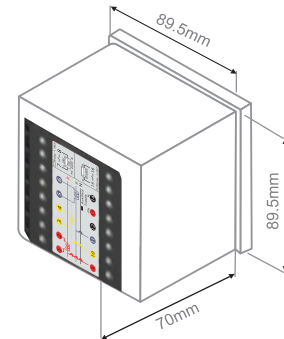

Multifunction Meter Dimensions

Harmonizer's Multifunction series power meters are easy-to-operate, compact in size, cost effective meters that offer the basic measurement capabilities required to monitor an electrical installation.

Characterized by their rugged construction, compact size, and low installation costs, these state-of-the-art multi-function meters are ideal for control panels, motor control centers and genset panels.

Multifunction series power meter is available in four versions to better fit specific applications:

- MF09 Series
- MF28 Series
- MF42 Series
- MF48 Series

Applications:

- Power monitoring operations.
- Load studies and circuit optimisation.
- Equipment monitoring and control.
- Preventative maintenance.

MAIN CHARACTERISTICS

● Accurate Metering

The meter conforms to accuracy class 1.0 / 0.5

● Easy to Read Display

The bright, alphanumeric, 15mm high LED display provides 3 lines for measurement values with 4 digits per line. The display auto-scales for Kilo, Mega and Giga values. Auto scrolling mode allows for easy reading.

● Quick And Easy Installation

Setup is done through the front panel keys. Direct connection for metering voltage inputs up to 480 Vac L-L.

ENERGY SAVINGS:

- Measure efficiency, reveal opportunities and verify savings
- Sub-bill tenants for energy costs
- Allocate energy costs to departments or processes
- Reduce peak demand surcharges
- Reduce power factor penalties
- Leverage existing infrastructure capacity & avoid over-building

ENERGY AVAILABILITY AND RELIABILITY:

- Verify the reliable operation of equipment.
- Improve response to power quality-related problems

● Colour-coded Terminal Board Labeling

The colour - coded label on the terminal board helps ensure accurate wiring.

● Secure Settings

Safeguard access to setup parameters with unique password protection. A keypad lock lets you display a user selected page by default.

Multi-function Meters

Selection guide		MF09	MF28	MF42	MFRR42	MF48
General					(With 2 Relay O/P)	
Use on LV and HV systems		■	■	■	■	■
Accuracy of the meter		□	□	□	□	□
Number of samples per cycle		50 at 50 Hz	50 at 50 Hz	50 at 50 Hz	50 at 50 Hz	50 at 50 Hz
Instantaneous rms values						
Current,	Total, Per phase & Neutral	■	■	■	■	■
Voltage,	Average, Phase to Neutral & Phase to Phase	—	■	■	■	■
Frequency,		—	■	■	■	■
Active power (W)	Total & per phase	* ■	* ■	■	■	■
Reactive power (VAR)	Total & per phase	—	—	■	■	■
Apparent power (VA)	Total & per phase	* ■	* ■	■	■	■
Power factor,	Average & per phase	—	■	■	■	■
Unbalance,	Current, voltage	■	■	■	■	■
Phase angle,	Between V & I, Ph1, Ph2, Ph3	—	—	■	■	■
RPM,	For generator only, speed calculated on generator voltage output and number of machine poles.	—	■	■	■	—
Energy values						
Active (Wh)		* ■	* ■	■	■	■
Reactive VARh)		—	—	■	■	■
Apparent energy (VAh)		* ■	* ■	■	■	■
Export / Import		—	—	—	—	■
Power quality measurements						
Total harmonic distortion %	Current, voltage, per phase	—	■	■	■	■
Other measurements						
Run hours	Operating time for load in hours	—	■	■	■	—
ON hours	Operating time for meter in hours	—	—	■	■	—
INTR	Number of interrupts	—	—	■	■	—
Relay o/p (2 Relay program able on (V/A/F/PF/W/VA)						
Relay - 1				□	■	
Relay - 2			—	□	■	—
Display						
LED display		■	■	■	■	■
Communication						
RS-485 port		—	□	□	□	□
Modbus protocol		—	□	□	□	□
Caliberation						
LED Pulse Output for Caliberation check		■	■	■	■	■

■ By Default □ Optional Features — Not Available
 * W/Va & Wh/Vah one will be selected programmable

Ordering Selection

	MF09	MF28	MF42	MFRR42	MF48
Class 1.0 without port	HA0910MF	HA2810MF	HA4210MFM		HA4810MF
Class 1.0 with port	HA0910MFR	HA2810MFR	HA4210MFMR	HA4210MFRR	HA4810MFR
Class 0.5 without port	HA0905MF	HA2805MF	HA4205MF		HA4805MF
Class 0.5 without port	HA0905MFR	HA2805MFR	HA4205MFMR	HA4205MFRR	HA4805MFR

Tri-vector Meters



Tri-vector Meter

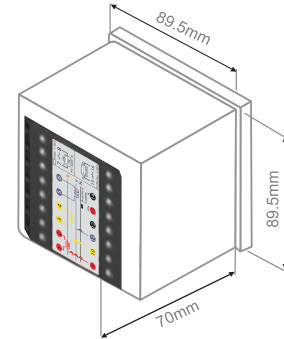

Tri-vector Meter Dimensions

Harmonizer's Tri-vector Meter series are easy-to-operate, compact in size, cost effective meters that offer the basic to highest measurement capabilities required to monitor an electrical installation.

Characterized by their rugged construction, compact size, and low installation costs, these state-of-the-art multi-function meters are ideal for control panels, motor control centers and all high end electrical requirements.

Tri-vector meters series is available in two different versions to better fit specific applications:

- TVM51 Series
- TVM44 Series

Applications:

- Power monitoring operations
- Load studies and circuit optimisation
- Equipment monitoring and control
- Preventative maintenance
- Import / Export energy calculation
- Demand Calculation.

MAIN CHARACTERISTICS

● Accurate Metering

The meter conforms to accuracy class 1.0 / 0.5

● Easy to Read Display

The bright, alphanumeric, 15mm high LED display provides 3 lines for measurement values with 4 digits per line. The display auto-scales for Kilo, Mega and Giga values. Auto scrolling mode allows for easy reading.

● Quick And Easy Installation

Setup is done through the front panel keys. Direct connection for metering voltage inputs up to 480 Vac L-L.

ENERGY SAVINGS:

- Measure efficiency, reveal opportunities and verify savings
- Sub-bill tenants for energy costs
- Allocate energy costs to departments or processes
- Reduce peak demand surcharges
- Reduce power factor penalties
- Leverage existing infrastructure capacity & avoid over-building

ENERGY AVAILABILITY AND RELIABILITY:

- Verify the reliable operation of equipment.
- Improve response to power quality-related problems

● Colour-coded Terminal Board Labeling

The colour - coded label on the terminal board helps ensure accurate wiring.

● Secure Settings

Safeguard access to setup parameters with unique password protection. A keypad lock lets you display a user selected page by default.

Tri-vector Meters

Selection guide	TVM51	TVM44
General		
Use on LV and HV systems	■	■
Accuracy of the meter	□	□
Number of samples per cycle	50 at 50 Hz	50 at 50 Hz
Instantaneous rms values		
Current, Total, Per phase & Neutral	■	■
Voltage, Average, Phase to Neutral & Phase to Phase	■	■
Frequency,	■	■
Active power (W) Total & per phase	■	■
Reactive power (VAr) Total & per phase	■	■
Apparent power (VA) Total & per phase	■	■
Power factor, Average & per phase	■	■
Unbalance, Current, voltage	■	■
Phase angle, Between V & I, Ph1, Ph2, Ph3	■	■
RTC	■	■
Load Survey Facility	—	—
Energy values		
Active (Wh)	■	■
Reactive (VARh)	■	■
Apparent energy (VAh)	■	■
Export / Import	■	—
Demand	■	■
Power quality measurements		
Total harmonic distortion % Current, voltage, per phase	■	■
Display		
LED display	■	■
Communication		
RS-485 port	□	□
Modbus protocol	□	□
Optical Communication	■	■
Caliberation		
LED Pulse Output	■	■

■ By Default □ Optional Features — Not Available

Ordering Selection

	TVM51	TVM44
Class 1.0 without RS 485	HA5110TVM	HA4410TVM
Class 1.0 with RS 485	HA5110TVMR	HA4410TVMR
Class 0.5 without RS 485	HA5105TVM	HA4405TVM
Class 0.5 with RS 485	HA5105TVMR	HA4405TVMR

Demand Controller



Demand Controller

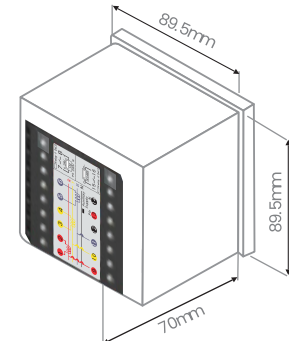

Demand Controller Dimensions

Smart Demand Controllers are easy-to-operate, compact in size, cost effective meters that offer the basic measurement capabilities required to monitor an electrical installation. Characterized by their rugged construction, compact size, and low installation costs, these state-of-the-art Smart Demand Controllers are ideal for use in Industrial & Commercial installations, not for domestic use.

The Smart Demand Controller offers comprehensive power and energy monitoring at the feeders and individual loads.

Smart Demand Controllers are available in two different versions to better fit specific applications:

- SDC51 Series

Applications:

- Maximum demand control
- Power monitoring operations
- Load studies and circuit optimisation
- Equipment monitoring and control
- Preventative maintenance

MAIN CHARACTERISTICS

● Accurate Metering

The meter conforms to accuracy class 1.0 / 0.5

● Easy to Read Display

The bright, alphanumeric, 15mm high LED display provides 3 lines for measurement values with 4 digits per line. The display auto-scales for Kilo, Mega and Giga values. Auto scrolling mode allows for easy reading.

● Quick And Easy Installation

Setup is done through the front panel keys. Direct connection for metering voltage inputs up to 480 Vac L-L.

ENERGY SAVINGS:

- Measure efficiency, reveal opportunities and verify savings
- Sub-bill tenants for energy costs
- Allocate energy costs to departments or processes
- Reduce peak demand surcharges
- Reduce power factor penalties
- Leverage existing infrastructure capacity & avoid over-building

ENERGY AVAILABILITY AND RELIABILITY:

- Verify the reliable operation of equipment.
- Improve response to power quality-related problems

● Colour-coded Terminal Board Labeling

The colour - coded label on the terminal board helps ensure accurate wiring.

● Secure Settings

Safeguard access to setup parameters with unique password protection. A keypad lock lets you display a user selected page by default.

Demand Controller

Selection guide	SDC51
General	
Use on LV and HV systems	■
Accuracy of the meter	□
Number of samples per cycle	50 at 50 Hz
Instantaneous rms values	
Current, Total, Per phase & Neutral	■
Voltage, Average, Phase to Neutral & Phase to Phase	■
Frequency,	■
Active power (W) Total & per phase	■
Reactive power (VAR) Total & per phase	■
Apparent power (VA) Total & per phase	■
Power factor, Average & per phase	■
Unbalance, Current, voltage	■
Phase angle, Between V & I, Ph1, Ph2, Ph3	■
RTC	■
Load Survey Facility	—
Other measurements	
Run hours Operating time for load in hours	■
ON hours Operating time for meter in hours	■
INTR Number of interrupts	■
Energy values	
Active (Wh)	■
Reactive (VARh)	■
Apparent energy (VAh)	■
Demand	■
Relay	
Relay - 1	■
Relay - 2	■
Power quality measurements	
Total harmonic distortion % Current, voltage, per phase	■
Display	
LED display	■
Communication	
RS-485 port	□
Modbus protocol	□
Optical Communication	■
Calibration	
LED Pulse Output	■

■ By Default □ Optional Features — Not Available

Ordering Selection

	SDC51
Class 1.0	HA5110SDC
Class 0.5	HA5105SDC

*TOD is stands for Time of Domain or Time of Use (TOU)

Electrical Characteristics (VAF & VAFP)

Electrical characteristics		
Type of measurement	True RMS up to the 22nd harmonic 50 samples per cycle at 50 Hz	
Measurement	Current and voltage	Class - 1.0 / Class - 0.5 accuracy
Frequency	Class - 0.1 / Class - 0.05 accuracy	
Power Factor Per Phase & Average	Class - 1.0 / Class - 0.5 accuracy	
Data update rate	1 sec	
Input-voltage characteristics	Inputs	V1, V2, V3, Vn
	Measured voltage	80 - 480 V AC L-L without PTs Up to 999 kV with external PTs
	Permissible overload	1.10 Un (480 V L-L)
	Burden	0.2 VA per phase max.
	Impedance	VLL - 4 Mohms, VLN – 2 Mohms
	Frequency range	45 - 65 Hz
Input-current CT ratings characteristics	Primary	1 A - 99.0 kA
	Secondary	1 A - 5 A
Measurement range	40 mA - 6 A (5 mA is the starting)	
Permissible overload	10 A continuous	
Burden	0.2 VA per phase max.	
Impedance	< 0.1 ohm	
Power supply	AC	44 - 277 V AC at 50 Hz/60 Hz
	DC	44 - 277 V DC
	Ride-through time	100 ms at 50V
	Burden	3 VA max.
Mechanical characteristics		
Weight	0.500 kg (shipping), 0.400 kg (unpacked)	
IP degree of protection	Front: IP 51; Back: IP 40	
Dimensions	Bezel: 96 x 96 mm Depth: 65 mm behind bezel Panel cutout: 92 x 92 mm	
Environmental conditions		
Operating temperature	-10°C to +60°C	
Storage temperature	-25°C to +70°C	
Humidity rating	5 to 95 % RH non-condensing	
Electromagnetic compatibility		
Electrostatic discharge	IEC 61000-4-2	
Immunity to electromagnetic RF fields	IEC 61000-4-3	
Immunity to electrical fast transients	IEC 61000-4-4	
Immunity to surge waves	IEC 61000-4-5	
Impulse voltage withstand capability	6kV for 1.2/50 µS per IS : 13779	
Display characteristics		
Integrated LED display	View1 parameters on 1 line, 4 digits display. Auto-scaling capability for Kilo,	

Electrical Characteristics

(TVM, Multifunction Meter,
Energy Meter & Demand Controller)



Electrical Characteristics			
Type of measurement		True RMS up to the 22nd harmonic 50 samples per cycle at 50 Hz	
Measurement	Current and voltage	Class - 1.0 / Class - 0.5 accuracy	
Accuracy*	Power	Active	Class - 1.0 / Class - 0.5 accuracy
		Reactive	Class - 2.0 / Class - 1.0 accuracy
		Apparent	Class - 1.0 / Class - 0.5 accuracy
Frequency		Class - 0.1 / Class - 0.05 accuracy	
Power factor		Class - 1.0 / Class - 0.5 accuracy	
Energy	Active	Class - 1.0 / Class - 0.5 accuracy	
	Reactive	Class - 2.0 / Class - 1.0 accuracy	
	Apparent	Class - 1.0 / Class - 0.5 accuracy	
	Demand	With 15 / 30 / 60 Min. Integration period	
* Additional error of 0.05% of full scale, for meter input current below 100 mA			
Data update rate		1 sec	
Input-voltage characteristics	Inputs	V1, V2, V3, Vn	
	Measured voltage	80 - 480 V AC L-L without PTs Up to 999 kV with external PTs	
	Permissible overload	1.10 Un (480 V L-L)	
	Burden	0.2 VA per phase max.	
	Impedance	VLL - 4 Mohms, VLN - 2 Mohms	
	Frequency range	45 - 65 Hz	
Input-current characteristics	CT ratings	Primary	1 A - 99.0 kA
		Secondary	1 A - 5 A
Measurement range		40 mA - 6 A (5 mA is the starting)	
Permissible overload		10 A continuous	
Burden		0.2 VA per phase max.	
Impedance		< 0.1 ohm	
Power supply	AC	44 - 277 V AC at 50 Hz/60 Hz	
	DC	44 - 277 V DC	
	Ride-through time	100 ms at 50V	
	Burden	3 VA max.	
Mechanical Characteristics			
Weight		0.500 kg (shipping), 0.400 kg (unpacked)	
IP degree of protection		Front: IP 51; Back: IP 40	
Dimensions		Bezel: 96 x 96 mm Depth: 65 mm behind bezel Panel cutout: 92 x 92 mm	
Environmental Conditions			
Operating temperature		-10°C to +60°C	
Storage temperature		-25°C to +70°C	
Humidity rating		5 to 95 % RH non-condensing	
Electromagnetic Compatibility			
Electrostatic discharge		IEC 61000-4-2	
Immunity to electromagnetic RF fields		IEC 61000-4-3	
Immunity to electrical fast transients		IEC 61000-4-4	
Immunity to surge waves		IEC 61000-4-5	
Impulse voltage withstand capability		6kV for 1.2/50 μS per IS : 13779	
Communication			
RS-485 port		2 terminals only Baud rate : Min. 9600bps Protocols: Modbus RTU	
Display Characteristics			
Integrated LED display		View 3 parameters together on 3 line, 4 digits per line display. Auto-scaling capability for Kilo, Mega values User-selectable default display page. Password protection for setup parameters.	

Wiring Diagram

Digital Communication:

RS 485 standard, communication capability using openmodbus RTU protocol. The meters can be multi dropped using RS 485 twisted pair.

The baud rate can be set from 1200 to 9600. RS 485 Half duplex isolated serial channel connection.

RS 485 Single Point Communication (Modbus)

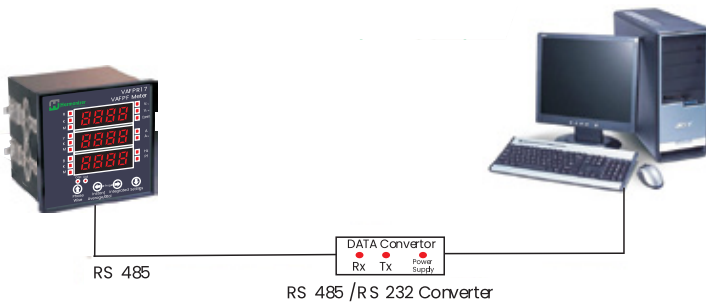

RS 485 Multi Point Communication (Modbus)

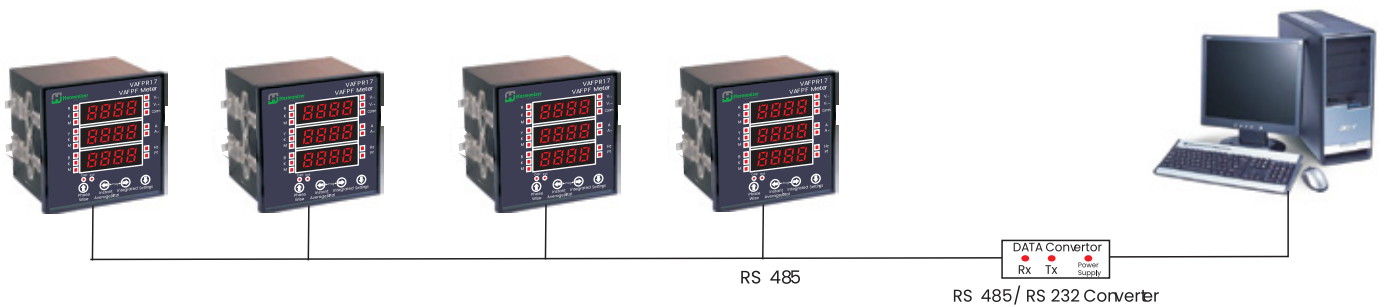

Wiring Connections

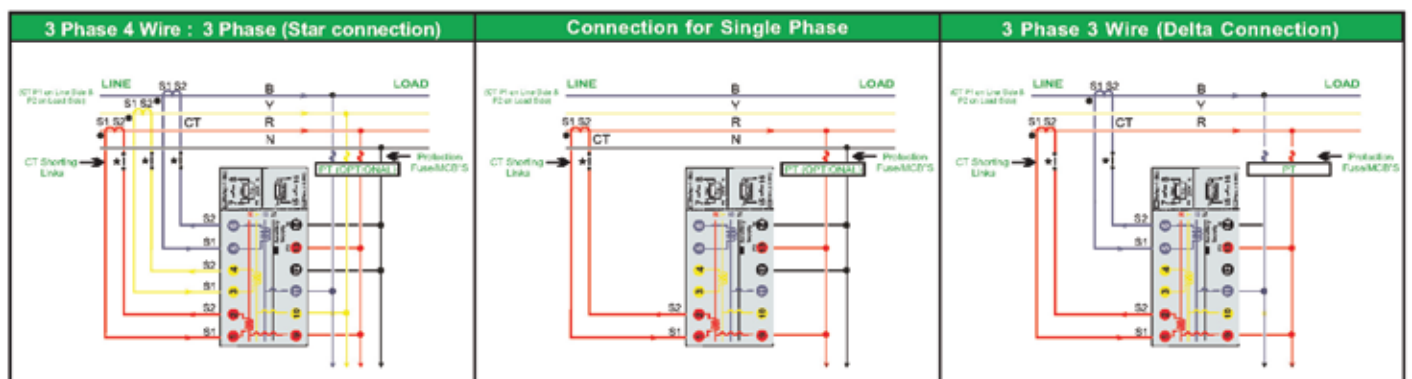



 8th Level, AL Ghaith Tower,
Hamdan Street, Abu Dhabhi
UAE

+91 96328 22929
sales@harmonizersolutions.com
info@harmonizersolutions.com
www.harmonizersolutions.com

 557, 15th Cross, 1st Main,
RHCS Layout, Nagarbhavi, Bangalore 560091
INDIA

 18 Nova Scotia Road,
Brampton
CANADA